

- Mounting styles:
 - for in-line mounting
 - straight valve cartridge
 - right angled valve cartridge

- Four sizes

- Poppet design

- One-way throttling check valve

- Three cracking pressures

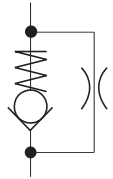

Functional Description

Check valves are used to allow flow in one direction and prevent flow in the other. The poppet design guarantees leak free closure and so it is allowed throttling only through orifice plate (5). The seat (3) is created directly in the housing (1) and the poppet (2) is pushed onto the seat by the compression spring (4). Design without spring pushes the poppet (2) on to the seat by pressure

of the fluid. The cracking pressure depends on the spring selected and the pressurised poppet surface area. Three cracking pressures are available. The valve without cracking pressure is also available (without spring). The basic surface treatment of the valve housing is zinc coated.

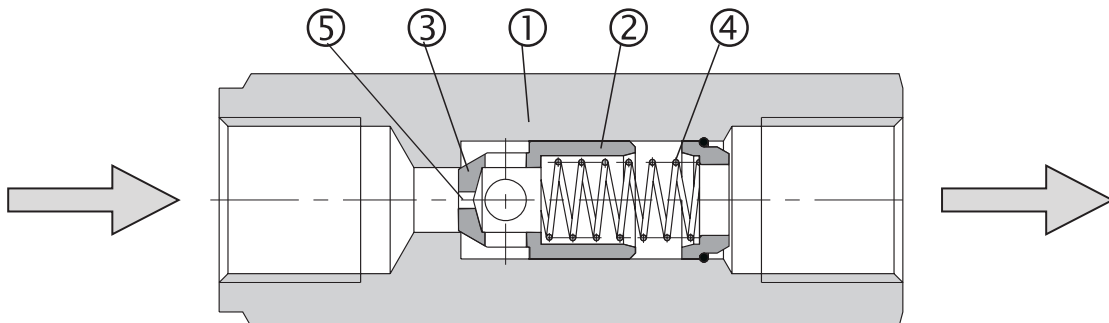

Ordering Code

VJS3 - [] - [] - [] - []		Orifice average	
Check Valve		020	0,20 mm (0,008 inch)
		050	0,50 mm (0,019 inch)
		080	0,80 mm (0,031 inch)
		100	1,00 mm (0,039 inch)
		150	1,50 mm (0,059 inch)
		200	2,00 mm (0,079 inch)
		300	3,00 mm (0,118 inch)
			Other orifices on demand
Nominal size			
06	06		
10	10		
16	16		
20	20		
Cracking pressure			
Without spring	000		
0,5 bar (7.25 PSI)	005		
1,5 bar (21.75 PSI)	015		
3,0 bar (43.51 PSI)	030		
		G1	Model
		M1	For in-line mounting - with G threads
		S	- with M threads
		02	- with SAE threads
		03	Straight valve cartridge
			Straight valve cartridge

Technical Data

Nominal size	mm	06	10	16	20
Maximum flow rate	L/min (GPM)	30 (7.9)	60 (15.9)	160 (42.3)	250 (66)
Maximum pressure	bar (PSI)	320 (4600)			
Cracking pressure	bar (PSI)	0,5 (7.25)	1,5 (21.75)	3,0 (43.51)	
Hydraulic fluid		Hydraulic oils of power classes (HL, HLP) to DIN 51524			
Fluid temperature range (NBR)	°C (°F)	-30 ... +100 (-22 ... +100)			
Viscosity range	mm ² /s (SUS)	20 ... 400 (98 ... 1840)			
Maximum degree of fluid contamination		Class 21/18/15 according to ISO 4406 (1999)			
Weight - model G1,M1,S - models 02, 03	kg (lbs)	0.11 (0.25) 0.05 (0.002)	0.34 (0.8) 0.09 (0.004)	0.52 (1.2) 0.22 (0.009)	0.95 (2.1) 0,26 (0.010)
Mounting position		optional, in case of construction without spring			

Δp-Q Characteristics

Measured at $v = 32 \text{ mm}^2/\text{s}$ (156 SUS)

Pressure drop Δp related to flow rate.

Nominal size 06

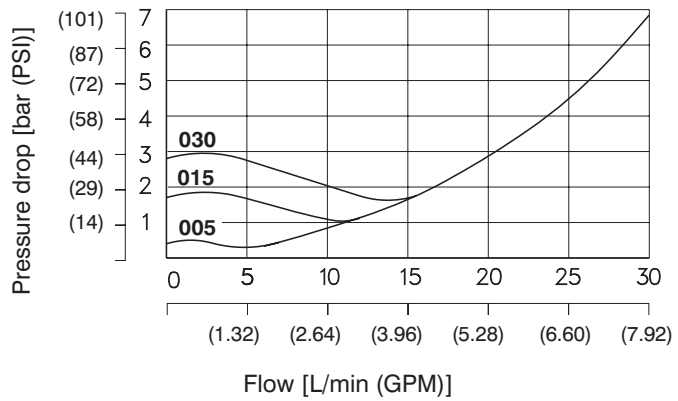

Nominal size 10

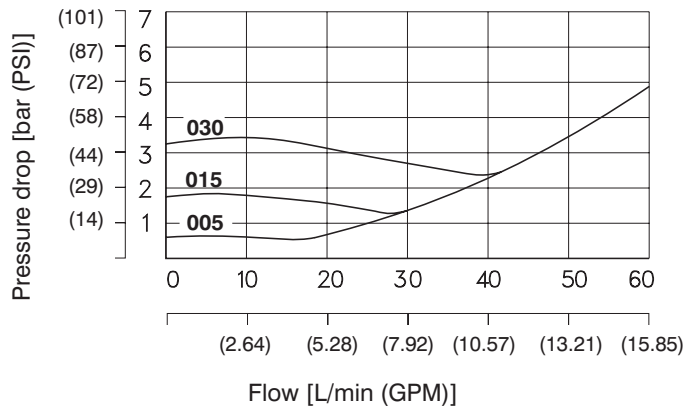

Δp-Q Characteristics

Measured at $v = 32 \text{ mm}^2/\text{s}$ (156 SUS)

Nominal size 16

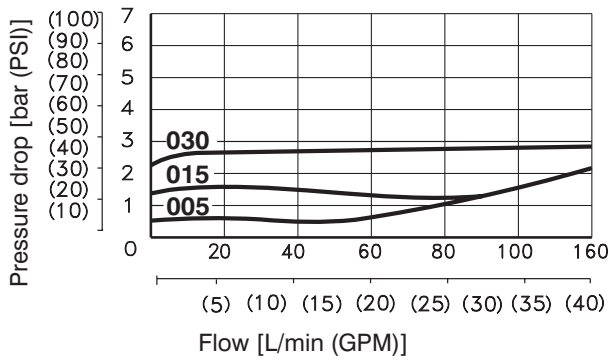

Nominal size 20

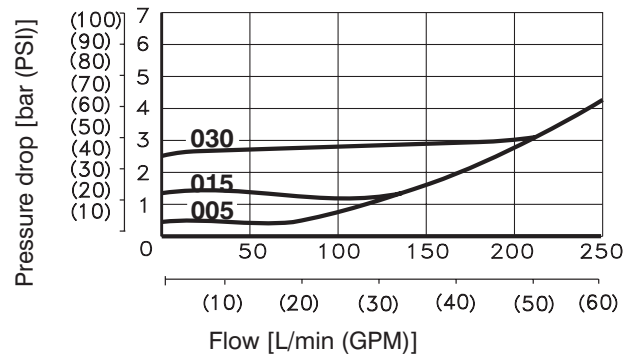

Valve Dimensions

Dimensions in millimetres and inches (in brackets)

Model G1

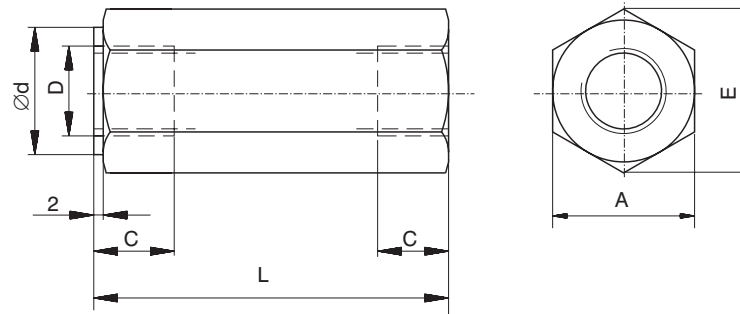

Model 02

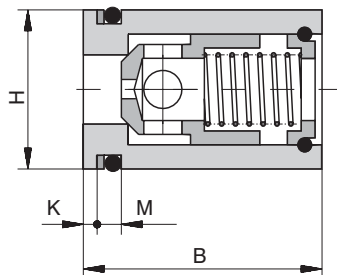

Model 03

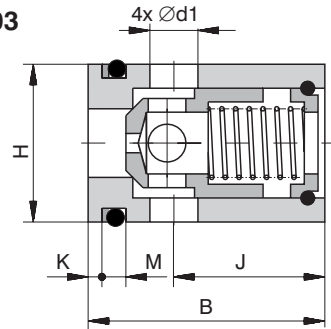

Size	A	B	C	D			Ød
				G1	M1	S	
06	19 (0.748)	27 - 0,2 (1.063-0.008)	12 (0.47)	G 1/4	M14x1,5	SAE-6, 9/16-18	19 (0.75)
10	30 (1.181)	32 - 0,2 (1.260-0.008)	14 (0.55)	G 1/2	M18x1,5	SAE-8, 3/4-16	30 (1.18)
16	36 (1.417)	45 - 0,2 (1.772-0.008)	16 (0.63)	G 3/4	M27x2	SAE-12, 1 1/16-12	36 (1.42)
20	46 (1.811)	45 - 0,2 (1.772-0.008)	18 (0.71)	G 1	M33x2	SAE-16, 1 5/16-12	46 (1.81)
Size	E	H	J	K	L	M	
06	22 (0.866)	Ø20 (0.787) f8	18 (0.709)	1.6 (0.063)	58 (2.28)	4.4+0.2 (0.173+0.0079)	
10	34.5 (1.358)	Ø25 (0.984) f8	20 (0.787)	1.6 (0.063)	72 (2.83)	4.4+0.2 (0.173+0.0079)	
16	41.5 (1.634)	Ø35 (1.378) f8	27 (1.063)	2.2 (0.087)	85 (3.35)	5.3+0.2 (0.209+0.0079)	
20	53 (2.087)	Ø40 (1.575) f8	25 (0.984)	2.2 (0.087)	98 (3.86)	5.3+0.2 (0.209+0.0079)	

Cavity

Dimensions in millimetres and inches (in brackets)

(length according to distance ring)

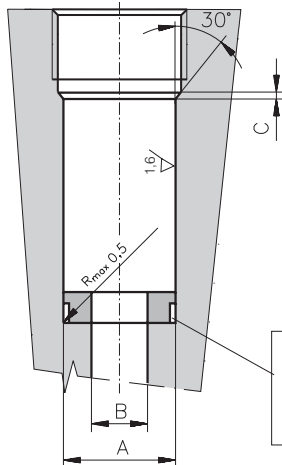
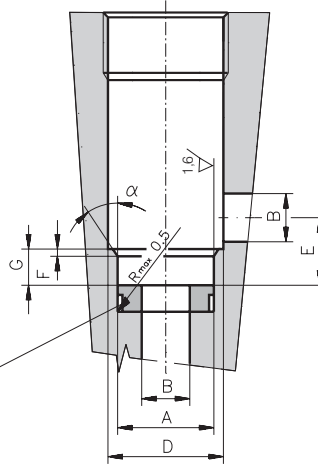
Model 02**Model 03**

If the hole cannot be reamed to the bottom, the use of a distance ring is recommended.

Size	A	B	C	D*	E	F	G	α
06	$\varnothing 20$ (0.787+0.0013) H8	$\varnothing 06$ (0.236)	2 (0.079)	$\varnothing 26$ (1.024)	10.5 (0.413)	1 (0.039)	7-0.3 (0.276-0.0118)	20 °
10	$\varnothing 25$ (0.984+0.0013) H8	$\varnothing 10$ (0.394)	2 (0.079)	$\varnothing 32$ (1.260)	14 (0.551)	1.5 (0.059)	8+0.2 (0.315+0.0079)	30 °
16	$\varnothing 35$ (1.378+0.0015) H8	$\varnothing 16$ (0.630)	2 (0.079)	$\varnothing 44$ (1.732)	22 (0.866)	2 (0.079)	13+0.2 (0.512+0.0079)	30 °
20	$\varnothing 40$ (1.575+0.0015) H8	$\varnothing 20$ (0.787)	2 (0.079)	$\varnothing 48$ (1.890)	25 (0.984)	2 (0.079)	14+0.2 (0.551+0.0079)	30 °

SAE-Port Cavities

Dimensions in millimeters and inches (in brackets)

ISO 11926, SAE J1926, MS 16142

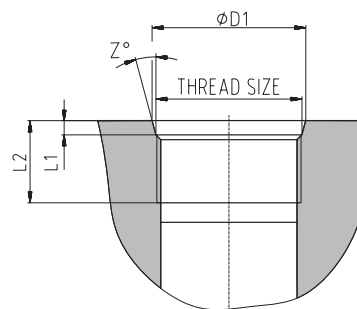

Type	Thread size	$\varnothing D1$	L1	L2	Z°
SAE-6	9/16-18 UNF-2B	15.6 (0.614)	2.5 (0.098)	13 (0.512)	12
SAE-8	3/4-16 UNF-2B	20.6 (0.811)	2.5 (0.098)	15 (0.591)	15
SAE-12	1 1/16-12 UN-2B	29.2 (1.150)	2.5 (0.098)	19 (0.748)	15
SAE-16	1 5/16-12 UN-2B	35.5 (1.398)	3.3 (0.130)	19 (0.748)	15

Spare Parts

Seal kit for Model 02 and Model 03

Size	O-Ring - NBR	Back-up ring		Order number
06	15,08 x 2,62	BBP 80B113-N9	14,66 x 19,02 x 1,14	22701100
10	20 x 2,65	BBP 80B116-N962N	19,43 x 23,79 x 1,14	15954600
16	28 x 3,55	BBP 80B216-N9	8,98 x 34,98 x 1,02	15954700
20	32,92x3,53	BBP 80B219-N90	33,88 x 39,88 x 1,02	22701400

Caution!

- The packing foil is recyclable.
- The technical information regarding the product presented in this catalogue is for descriptive purposes only. It should not be construed in any case as a guaranteed representation of the product properties in the sense of the law.

ARGO-HYTOS s.r.o. CZ - 543 15 Vrchlabí
 Tel.: +420-499-403111, Fax: +420-499-403421
 E-mail: sales.cz@argo-hytos.com
 www.argo-hytos.com