

- Load-holding without leakage
- Low pressure drop
- Optional pilot seal
- The valve should be mounted as close as possible to the actuator
- Fits the same cavity as the R3 overcentre valve

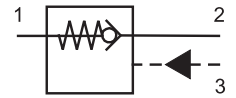

Functional Description

The design of the valve fitted with conical seat ensures hermetical closing in one direction and in the other direction of flow with a small pressure drop. The valve remains shut off closely if the pressure in channel (1) is equal to or higher than the pressure in channel (2) and no pressure and / or insufficient pressure only is exerted in the channel (3). As soon as the pressure in the channel (2) exceeds the pressure in the channel (1) including pressure caused by the spring the valve opens the flow from (2) to (1). If the liquid has to flow through the valve from (1) to (2) the control pressure should be introduced in the channel (3). As soon as this pressure attains a necessary value the control gate valve is shifted against the spring and moves the valve cone out of the seat. At calculating the control pressure

it is necessary to take into consideration that pressure in the channel (2) will increase the control pressure by the same value multiplied by an effective differential area. This effective differential area has a value of $1 - 1/4$ at a rate of control areas of 4:1.

As for appropriate basic surface finish the external parts are zinc coated.

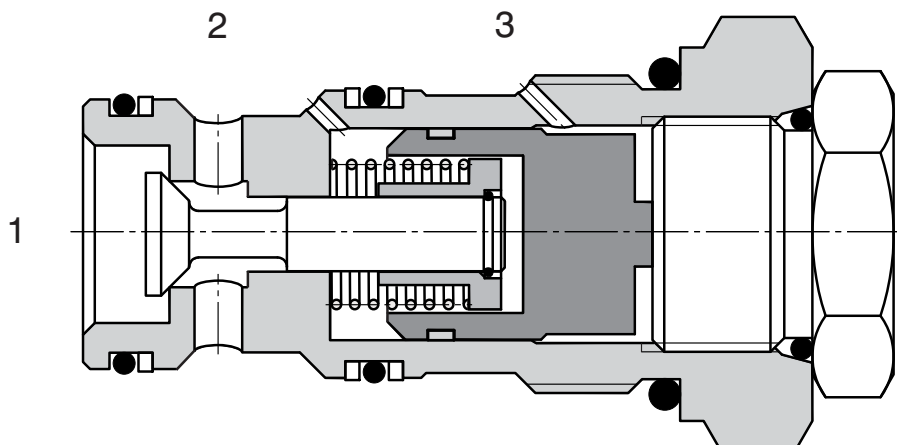

Ordering Code

SC5H-R3/I

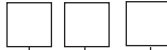

Pilot Operated Check Valve

No designation

Seals
NBR

Pilot ratio
Standard

4:1

4

No designation
S

Optional pilot seal
without seal
with seal

Technical Data

Cavity		M27 x 1.5
Maximum flow	L/min	90
Pilot ratio		4:1
Max. pressure	bar	350
Pressure drops	bar	see $\Delta p - Q$ characteristics
Hydraulic fluid		Hydraulic oil (HM, HV) according to DIN 51524
Fluid temperature range	°C	-20 ... +90
Viscosity	mm ² /s	20 400
Maximum degree of fluid contamination		according to ISO 4406, Class 21/18/15
Weight	kg	0.27
Maximum valve tightening torque in valve body or in control block	Nm	60 ⁺²
Mounting position		Unrestricted

Δp -Q Characteristics

Measured at $v = 40 \text{ mm}^2/\text{s}$

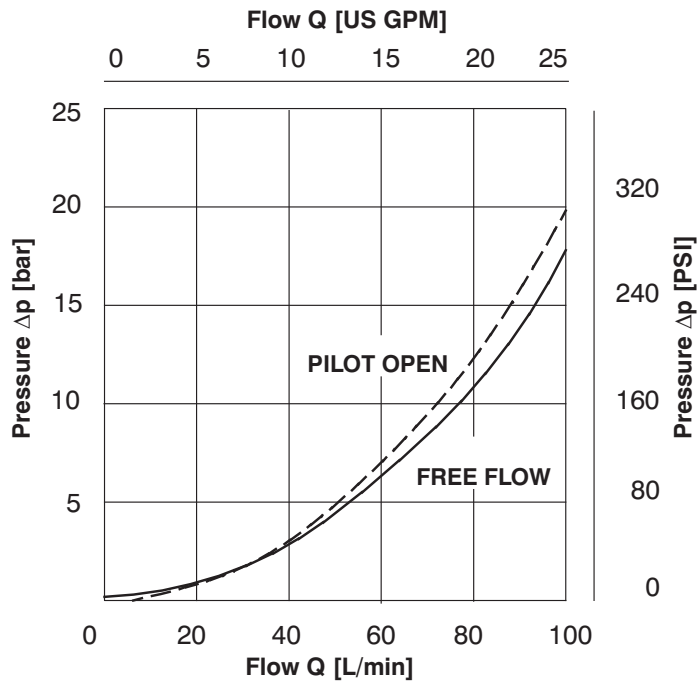

Valve Bodies

Measurements in millimeters

ISO A

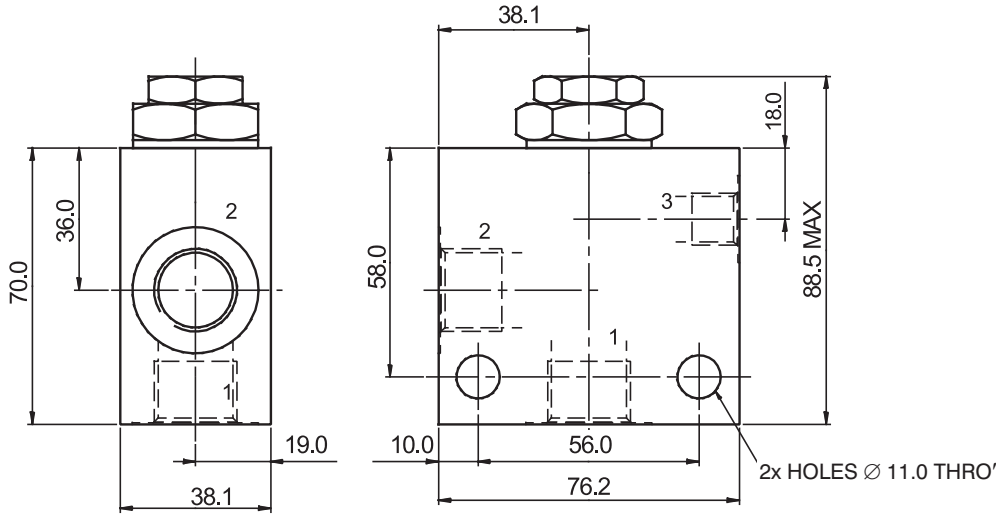
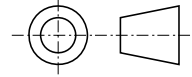

Body without valve			
Material	Ports	Port size	Type code
Aluminium	1, 2	G1/2	SB-R3-0105AL
	3	G1/4	
	1, 2	SAE 10, 7/8-14	SB-R3-0106AL
	3	SAE 6, 9/16-18	
Steel	1, 2	G1/2	SB-R3-0105ST
	3	G1/4	
	1, 2	SAE 10, 7/8-14	SB-R3-0106ST
	3	SAE 6, 9/16-18	

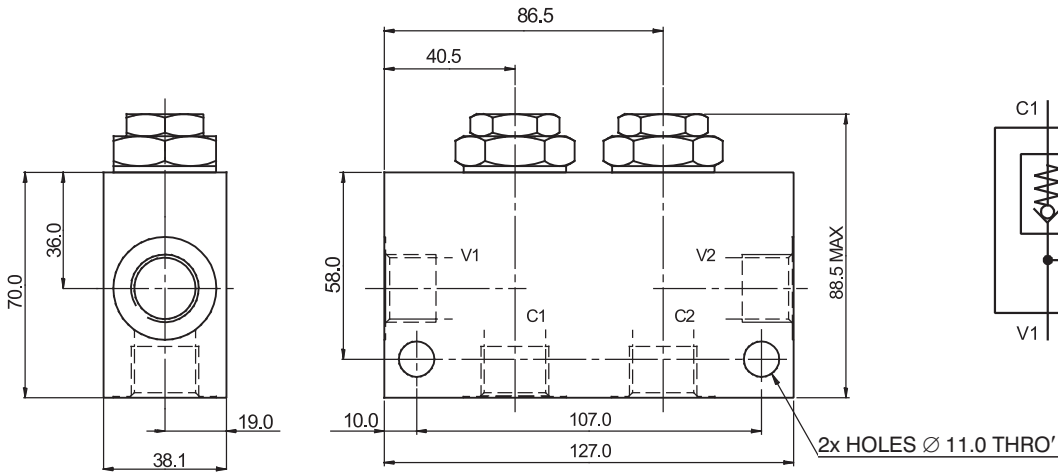

Dual body without valve			
Material	Ports	Port size	Type code
Aluminium	C1, C2, V1, V2	G1/2	SB-R3-0205AL
	C1, C2, V1, V2	SAE 10, 7/8-14	SB-R3-0206AL
Steel	C1, C2, V1, V2	G1/2	SB-R3-0205ST
	C1, C2, V1, V2	SAE 10, 7/8-14	SB-R3-0206ST

The use of aluminium bodies is limited to a maximum operating pressure of 210 bar.

Spare Parts

Seal kits on request.

Caution!

- The packing foil is recyclable.
- The technical information regarding the product presented in this catalogue is for descriptive purposes only. It should not be construed in any case as a guaranteed representation of the product properties in the sense of the law.

ARGO-HYTOS s.r.o. CZ - 543 15 Vrchlabí
 Tel.: +420-499-403111, Fax: +420-499-403421
 E-mail: sales.cz@argo-hytos.com
 www.argo-hytos.com